

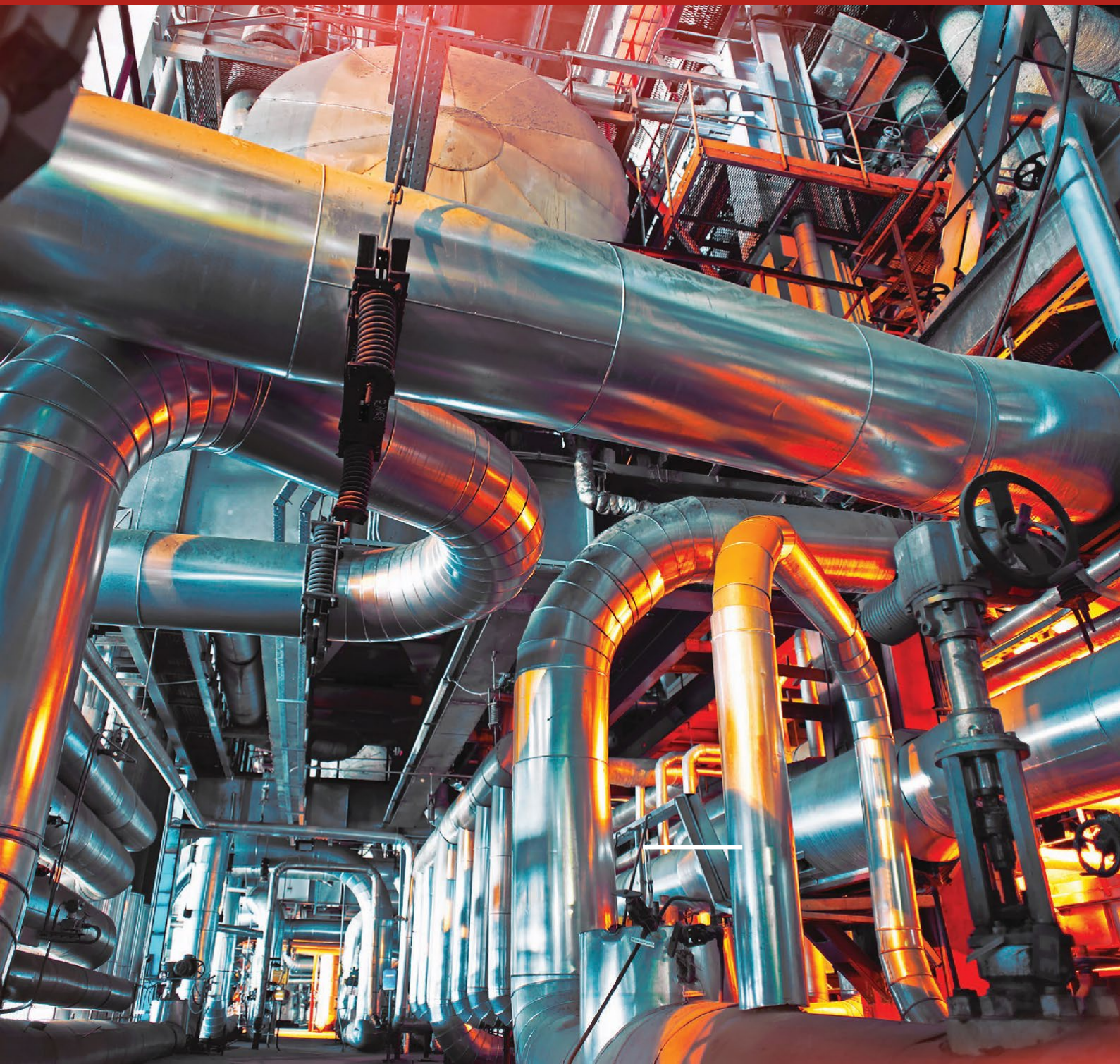

A GUIDE TO YOUR ENGINEERING INSPECTIONS



Contents

Inspection information at your fingertips	3
Lifting Equipment	5
Pressure Systems	15
Electrical	24
Local Exhaust Ventilation	32
Power Presses	38
Other Work Equipment	44
Frequently asked questions	52
Leave nothing to chance	56



We make sure everyone gets homesafe

We believe that there should never be a compromise with safety. In its simplest and most explicit form, industrial safety can be a matter of life or death. MAT Engineering Services will make Britain a safer place, for industry, for business, for people, whenever and wherever, right now and always.

The whole reason we exist is to keep people from harm's way. We assess, so we can protect. We're reliable too, which means the highest quality inspection. On time. Every time. Whatever the assignment. We pride ourselves on being where we're needed, when we're needed. That's just our thing.

We will do everything we can to keep Britain working, increasing plant and equipment safety and, in turn, their lifespan. At the same time, we'll help keep you legally compliant too.

This guide provides information about the legislation your machinery and equipment is covered by. We've details about how about often you'll need your plant inspecting and included some frequently asked questions.

The purpose of inspections and examinations is to make sure the equipment is safe for continued use; it does not replace maintenance. There are legal obligations on users of work equipment to ensure it is maintained in efficient working order.

For more detailed information on inspection requirements, or on any other aspects of engineering inspection or risk management, please contact us and we will be happy to help.



Lifting Equipment

Definitions

Lifting equipment is work equipment used for lifting and lowering loads. It includes the attachments used for anchoring, fixing or supporting equipment such as cranes, lifts, excavators and lift trucks.

Accessories for lifting includes any chain, rope, sling, or component kept for attaching loads to machinery for lifting.

Examination scheme means a suitable scheme drawn up by a competent person for the thorough examination of lifting equipment at such intervals as may be appropriate for the purpose described within the regulations.

Work equipment means any machine, appliance, apparatus, tool or installation for use at work.

Relevant Legislation

The requirements for the examination of lifting equipment are found within the Lifting Operations and Lifting Equipment Regulations 1998 (LOLER). LOLER applies over and above the more general requirements of the Provision and Use of Work Equipment Regulations 1998 (PUWER). Unlike previous legislation, which applies to specific industry sectors, PUWER and LOLER apply to all places of work.

LOLER covers work equipment that lifts or lowers a load. The following points need to be considered:

- The type of load being lifted
- The risk of the load falling and striking a person or object and the consequences
- The risk of the equipment striking a person or object and the consequences
- The risk of the lifting equipment failing or falling over whilst in use.

LOLER is concerned with many aspects of lifting operations and lifting equipment such as strength, stability and positioning of lifting equipment and the planning of lifting operations. However this guide is limited to the examination requirements of LOLER. An assessment of the risks associated with the equipment must be made to identify where the provision for thorough examination and inspection within LOLER applies.

The thorough examination of lifting equipment must be carried out by persons of sufficient competence who are independent and impartial to allow objective decisions to be made. MAT Engineering Services Limited can provide thorough examinations where required.

Different categories of examination are identified within LOLER:

Examinations should be carried out:

- Initially, before equipment is taken into service (there are some exceptions for CE marked new equipment)
- Post installation, where safety is dependent on correct installation
- Where lifting equipment is exposed to conditions which cause deterioration that could lead to a dangerous situation, periodic examinations are required
- Following any exceptional events such as an accident or long period without use.

Examination Frequency

LOLER continues to prescribe periods between thorough examinations of lifting equipment.

These are:

- Every six months for lifting equipment used for lifting/lowering persons. For example, passenger lifts, access platforms, window cleaning equipment
- Every six months for lifting accessories ('tackle'). For example, chain slings, eyebolts and shackles
- Every 12 months for all other lifting equipment not falling into either of the above categories. For example, cranes and lift trucks.

However, LOLER offers a 'risk based' approach to examination. This means that customers can arrange for a scheme of examination to be drawn up taking account of their specific equipment, environment and operations to specifically define the scope and frequency of ongoing thorough examinations based on foreseeable risk.



Excavators

Hydraulic excavators are used widely in the construction industry and are normally fitted with a bucket attachment. Machines use a diesel engine as a primary source of power whilst a hydraulic system controls movement of all the major functions.

Hydraulic excavators fall into two categories:

- 1) Centre post machines that slew 360 degrees and may be mounted on wheels or tracks. They utilise an articulated boom on which a variety of attachments can be fitted. This enables the machine to be used for crane duties, bucket (trenching) duties, magnet duties and grab duties.
- 2) Composite machines are normally known as back-hoe loaders. They include an articulated boom mounted to the rear of the vehicle that can slew through 180 degrees (back-actor or back-hoe) and a loading shovel/lifting forks mounted on the front of the machine. Whilst the capacity of the loading shovel is normally fixed, different sizes of bucket or lifting attachments may be used in conjunction with the back-actor.

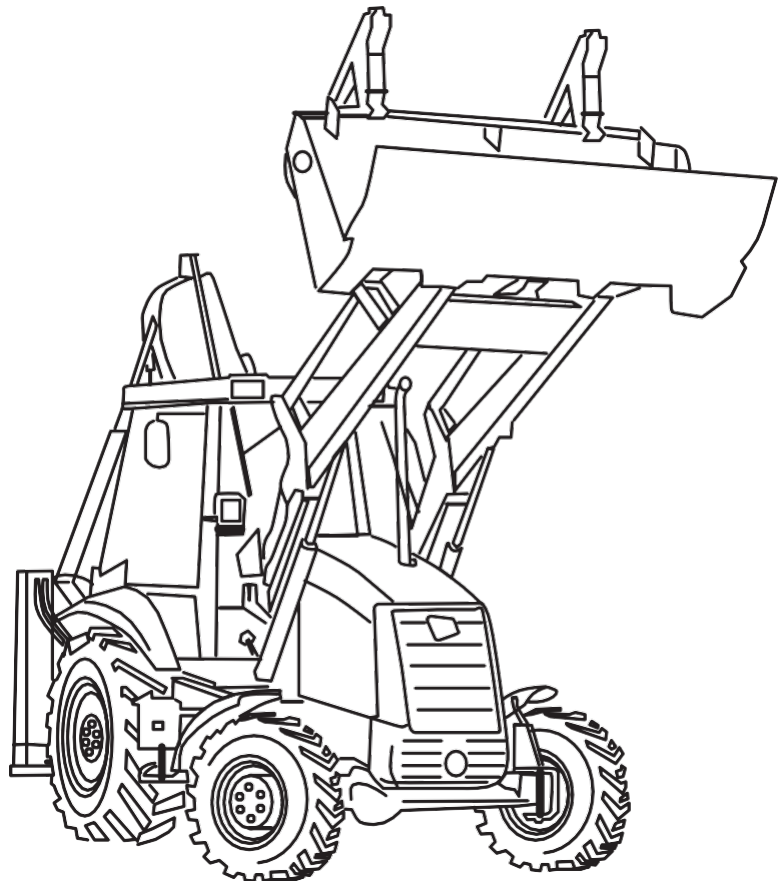

Lift Trucks

Lift trucks are used extensively across all industrial sectors, with capacities varying from one tonne to 50 tonnes. The larger machines are mainly used in freight handling (shipping containers), forestry and steel-making industries.

Lift trucks are normally fitted with a load fork (hence 'fork lift truck'), however, a variety of other attachments can be fitted to most trucks, for example, bale grabs, carpet poles, crate tines and man-riding working platforms. Side loaders are mainly used for lifting and transporting long bulky items such as stacks of timber. The lifting function simply raises the load onto a side deck, which forms an integral part of the truck. The load can then be transported significant distances.

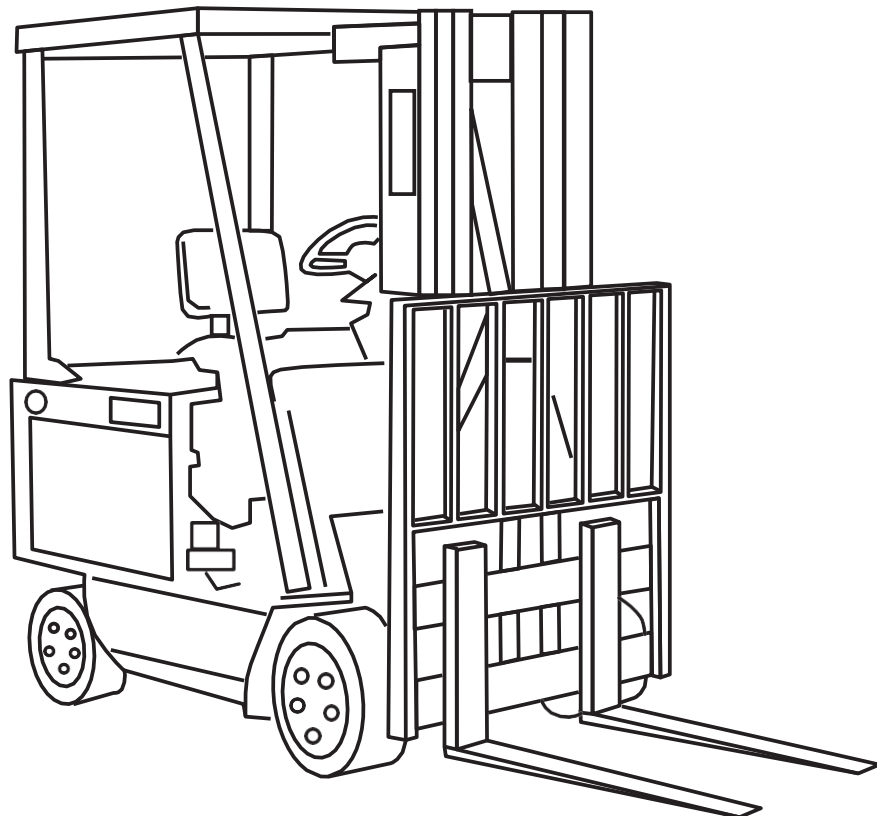

Mobile Elevating Work Platforms

Mobile elevating work platforms (MEWPs), also known as 'cherry pickers', 'beanstalks' and 'access platforms'. They are used in all sectors of industry and provide a temporary platform for persons working at heights.

All MEWPs have the capacity to move from one location to another either as a purpose built machine with integral road wheel steering facilities, or mounted on a lorry or van. MEWPs are normally electric/hydraulic or diesel hydraulic units and utilise a scissor mechanism, articulated jib or telescopic mast to lift a cage or platform to the desired position where the work is to be carried out. Controls are mounted on/in the platform/cage.

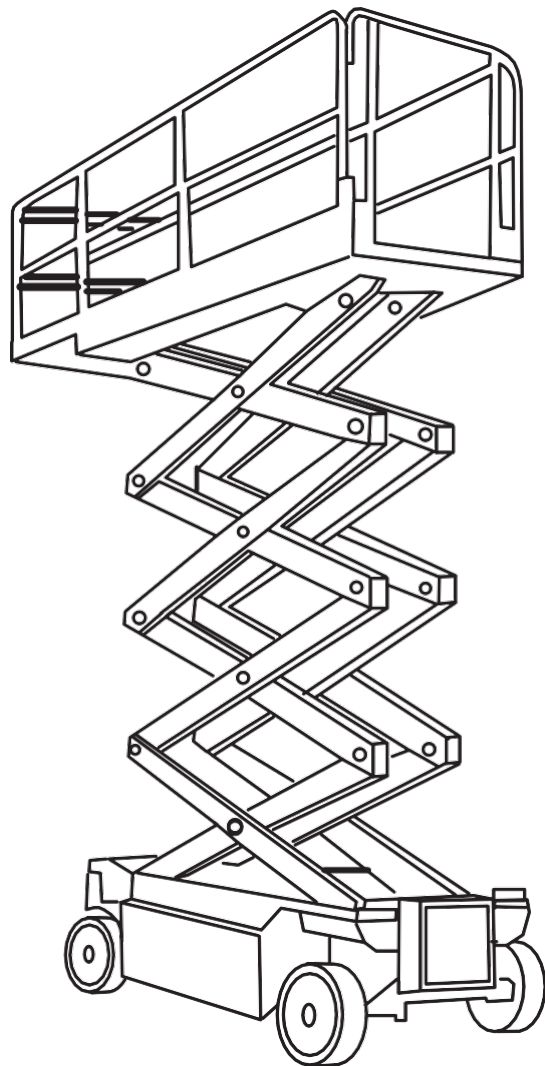

Gantry/Chain Blocks

Normally mounted on runway tracks or manual cranes, powered hoist blocks are widely used in all industry sectors. Normally electrically or pneumatically powered, these units hoist loads via a load hook and integral steel chain or wire rope. Lifting capacity can be as much as 10 tonnes.

Winches are of similar design and can be used for a variety of duties ranging from hauling loads horizontally to lifting or lowering loads in a vertical plane. Heavy-duty units used in the shipbuilding industry are capable of hauling thousands of tonnes. Small units fitted to road vehicles are frequently used for both hauling and lifting duties.

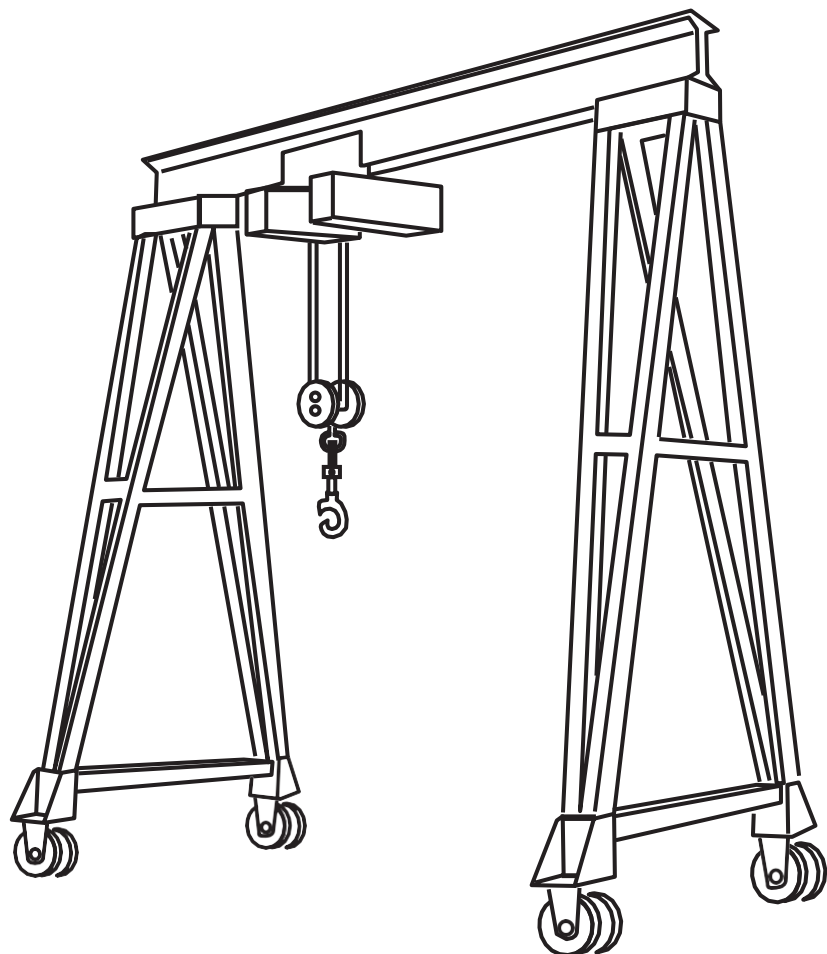

Mobile Cranes

These types of cranes are favoured by the crane hire industry as they can be used for a wide variety of lifting operations in many sectors of industry. Mobile cranes are normally self-erecting lorry-mounted machines incorporating outriggers for extra stability and a telescopic jib for improved reach. Modern machines utilise diesel hydraulic drive units. Whilst the average lifting capacity is about 50 tonnes, some mobile telescopic cranes are manufactured with a lifting capacity in excess of 1,000 tonnes.

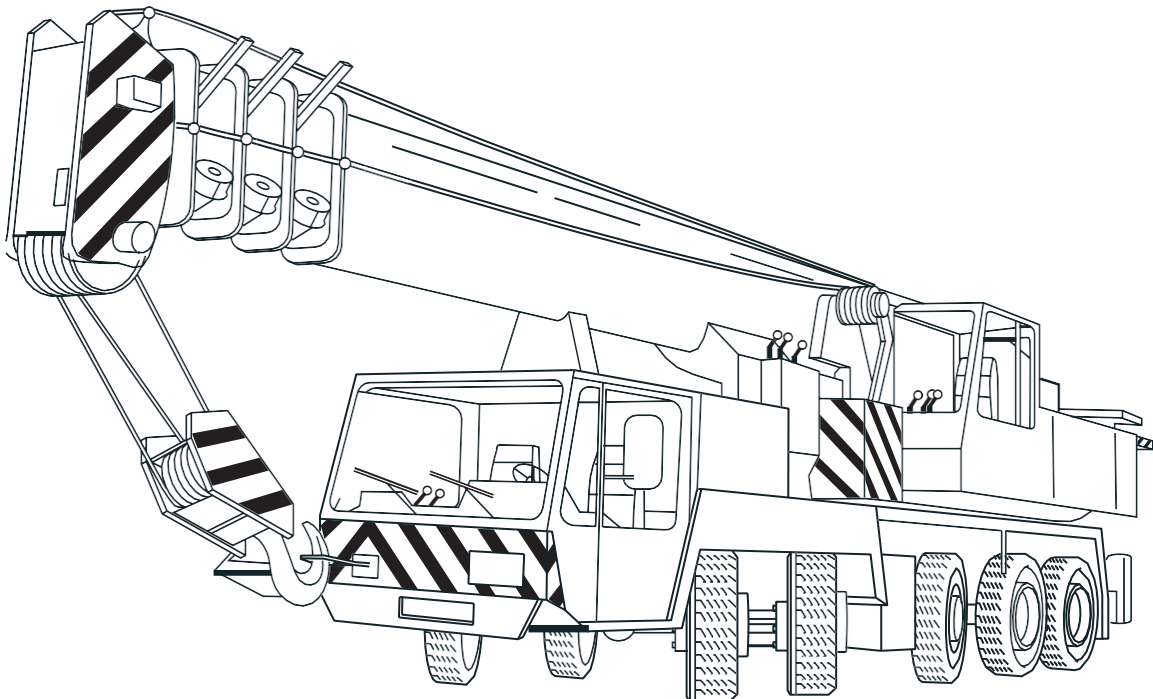

Frequently Asked Questions

Q. A common 'serious' defect on lift trucks is wear in excess of 10% at the fork heels. Why does the engineer have to report this defect and what can be done to rectify worn fork heels?

The engineer is bound by the guidance issued by the HSE and information within BS ISO 5057. Guidance is provided on inspection of fork arms, surface cracks, straightness of blade, fork angle, difference in height of fork tip and of set of fork arms etc. BS ISO 5057 rejects fork arms that are worn at the heel more than 10% of the original thickness of the metal.

We recommend repairs are only carried out by the fork arm manufacturer. If welding is carried out, the welding method will need to include welding preparation, pre-heating, stress relieving and re-heat treatment within the manufacturer's specification.

Use of mild steel materials and ordinary jobbing welding methods are likely to result in an unsatisfactory and unsafe repair. Most manufacturers do not even recommend welding at the heels of the forks to replace metal removed by wear as this only replaces the thickness and not the strength. Welding may in fact do further harm by mismatching of metals, localised heating and lack of heat treatment.

Q. How often is a 'thorough examination' required on lifting plant?

Under LOLER a 'thorough examination' is typically required every 12 months. Lifting attachments, accessories and machines for lifting persons need examination every six months.

Q. Can I lift a person on my lift truck?

The only acceptable use of a lift truck for lifting persons is in exceptional circumstances using a specifically designed and tested carrier or working platform. Purpose built units are normally available from the manufacturer of the truck.

A more appropriate method of working at heights should be employed such as permanent/temporary scaffold or a mobile elevating work platform.

A person should not be lifted on the forks, pallet or bucket on the front of a lift truck under any circumstances.

The recognised minimum examination frequency of a lift truck used to lift a person is six months.

Q. The 'thorough examination' highlighted a serious defect which has now been repaired. Does the item need to be examined again?

The competent person who undertakes the thorough examination states in his report that, 'subject to any remedial action to defects noted, which are or could become a danger to persons, the equipment is safe to operate'. Therefore when repaired, the equipment may be re-introduced back into service. However, the plant owner must ensure that the serious defect is repaired in accordance with the manufacturer's instructions and by persons competent to undertake such work.

Pressure Systems

Definitions

Relevant fluids include steam, gases under pressure and fluids that are artificially kept under pressure and become gases upon release into the atmosphere.

Pressure system means a system comprising one or more rigid pressure vessels with associated pipework and protective devices, pipework associated with a transportable pressure vessel, or a pipeline.

Written Scheme of Examination is a document that identifies the extent of the pressure system, outlines the examination requirements and frequency of inspection.

Relevant Legislation

Inspection requirements for pressure systems are consolidated within the Pressure Systems Safety Regulations 2000 (PSSR). The regulations apply to users and owners of systems containing 'relevant fluids'.

They require the system to be inspected in accordance with its 'Written Scheme of Examination'.

A Written Scheme of Examination is drawn up following a risk assessment of the system.

It must:

- Clearly define the extent of, and items of plant included in, the pressure system
- Detail the inspection frequency of relevant parts of the system
- Be drawn up and/or certified by a competent person such as MAT Engineering Limited.

In addition to out of service examination, which involves the system being closed down and vessels opened up, an in service examination is also usually required. This involves testing the system under pressure and is sometimes more frequent than the out of service examination.

Hot water boilers, operating at more than 100°C, fall within PSSR. However, it is recommended that all hot water boilers should be inspected. Refrigeration and air-conditioning plant with combined compressor motors exceeding 25kW fall within the regulations, but it is also prudent to regularly inspect items below this cut-off.

Examination Frequency

There is flexibility in establishing the frequency for out of service examinations permitted under the PSSR providing the risks allow. The Safety Assessment Federation publish guidance on the periodicity of examinations at www.safeduk.co.uk/technical-guides/pressure-equipment. The following can be used as an approximate guide.

Steam Boilers & Ovens	14 Months
Steam Pressure Plant	26 Months
Hot Water Boilers (>100°C)	14 Months
Air Pressure Plant	26/48 Months (in good conditions well maintained/dry plant could be 48 months)
Air condition & refrigerating plant (>25kW)	48 Months
Other Pressure Systems	26-144 Months

Horizontal Multitubular Steam Boiler

Horizontal multitubular steam boilers are sometimes referred to as package boilers or shell boilers. These items can range from 1m to 4m in diameter and are typically used for generating steam or high-pressure hot water to be used in various process/manufacturing processes.

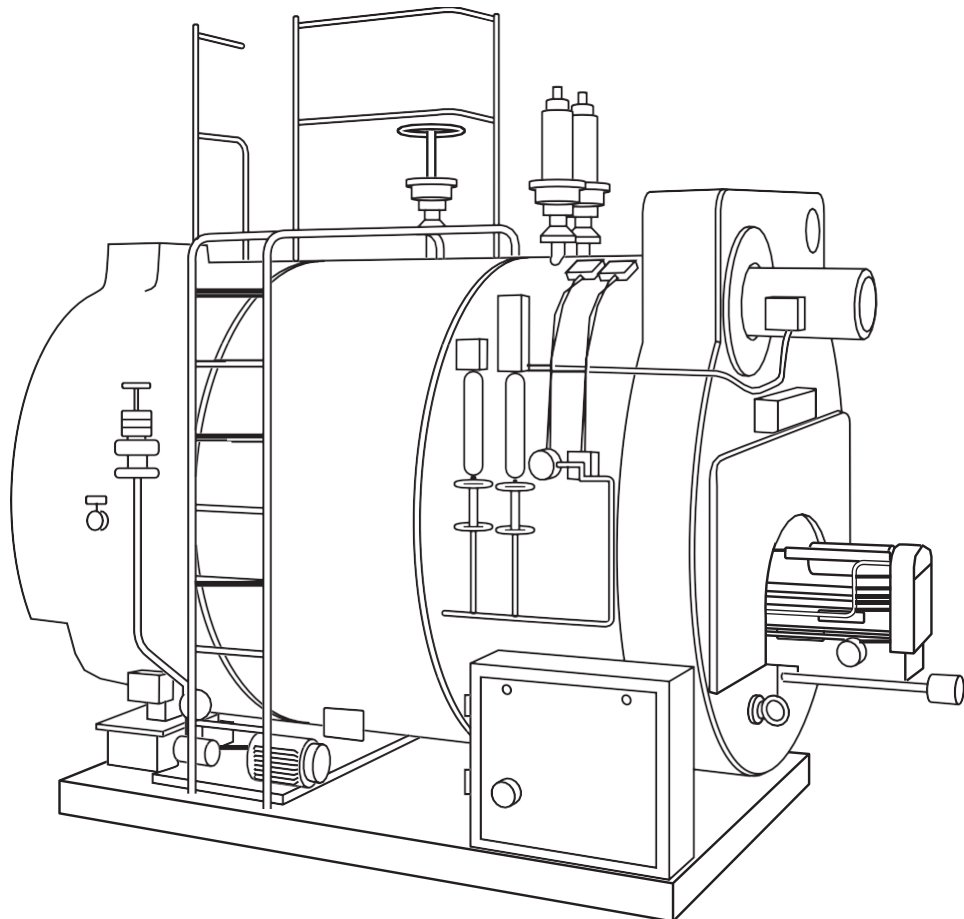

Refrigerating Plant

Refrigerating plant is usually used for air conditioning in office blocks, where chilled water is used to control the air's humidity. Larger and more complex types are used in the frozen food industry and retail (supermarkets) to both freeze and keep all types of food frozen.

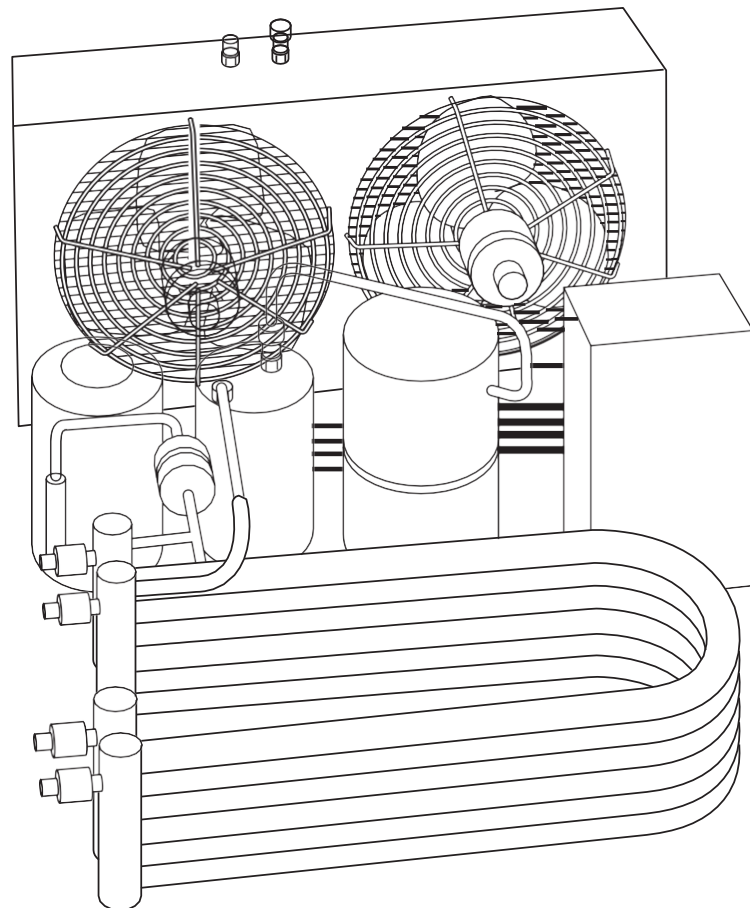

Heating Boilers

Heating boilers are in common use for all types of premises and can range from a central heating boiler, as seen in many homes, to very large cast iron sectional heating boilers for heating large office complexes.

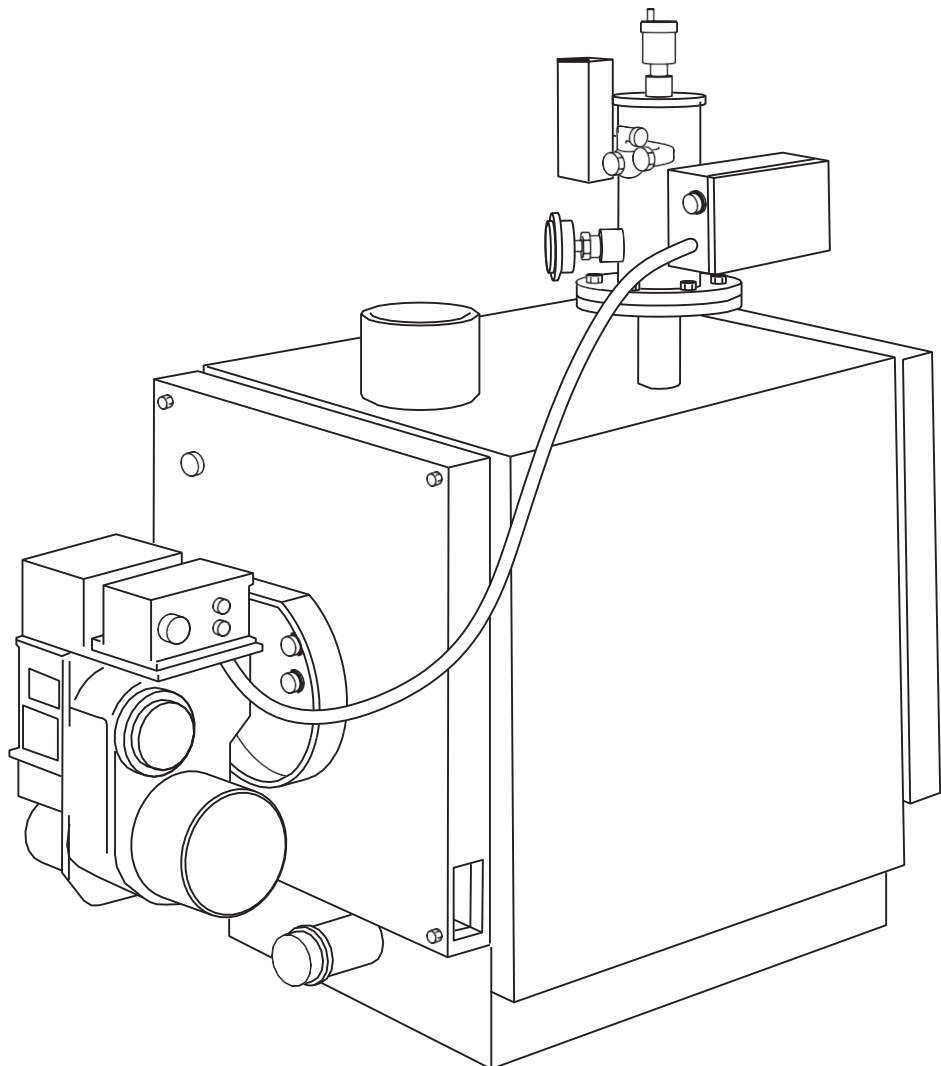

Air Receivers

Air receivers, commonly referred to as air compressors, air vessels and air tanks, are widely used. They are found in garages, tyre repair depots and anywhere that requires compressed air.

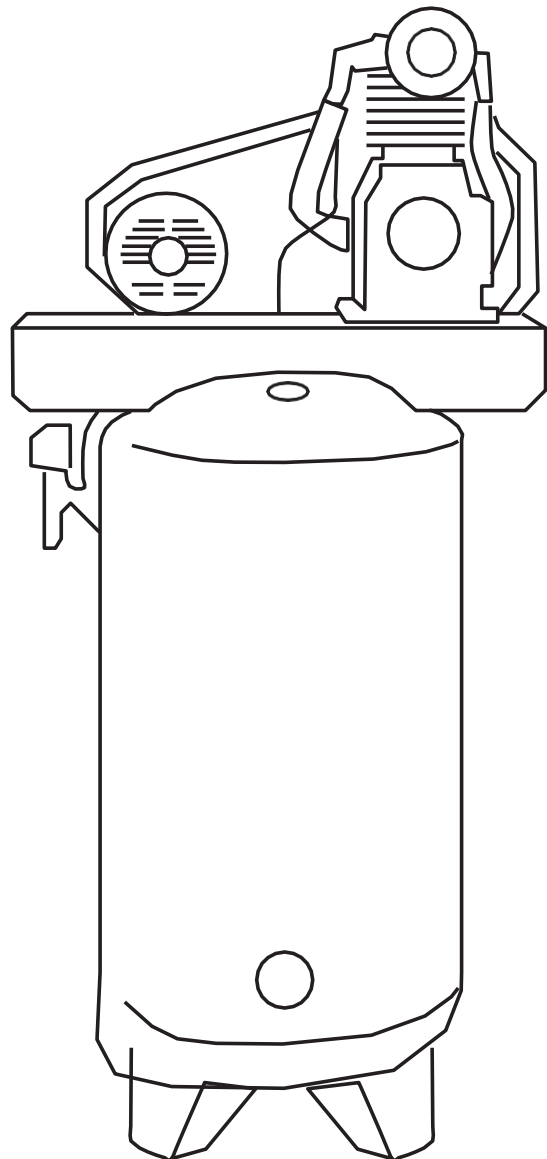

Jacketed Pans

Jacketed pans are usually open topped semi-circular pans with a heating space surrounding the pan, typically steam heated and used for cooking food or where heat is necessary to assist in a process.

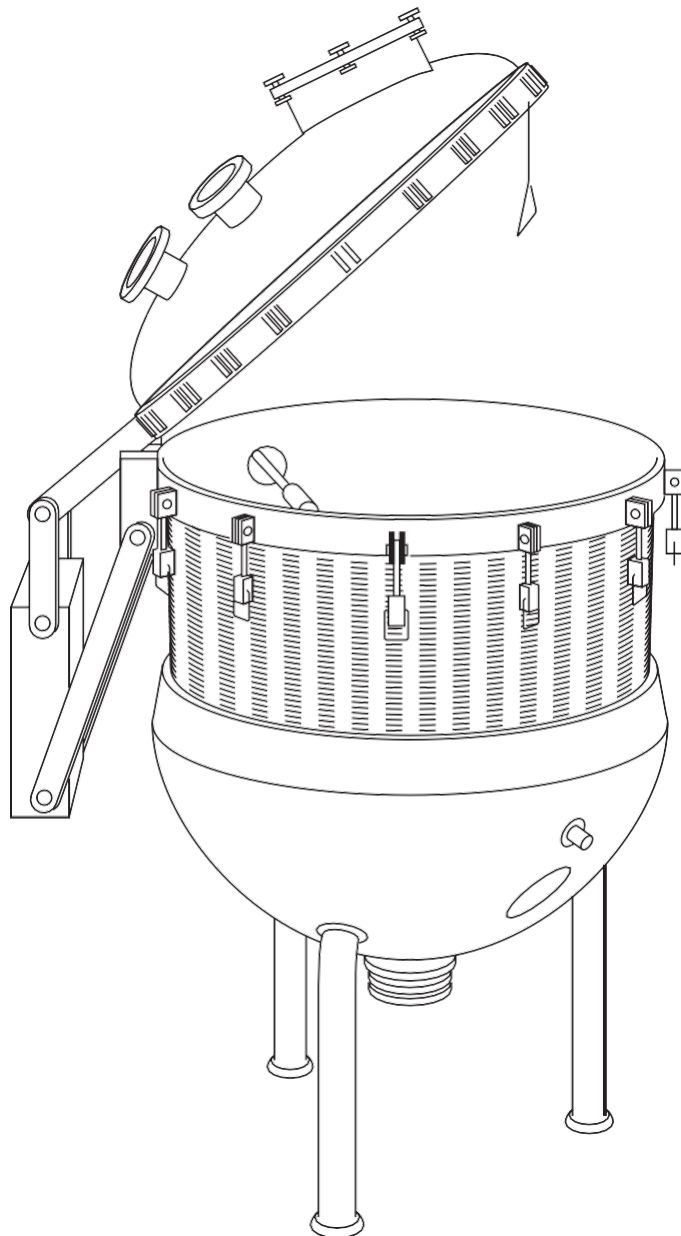

Frequently Asked Questions

Q. Do all air receivers need to be inspected? What is the calculation for deciding when an air receiver needs to comply with statutory regulations?

Within the PSSR the question is asked: is the pressure x volume of the largest pressure vessel in the system greater than 250 bar litres? If YES - then a written scheme and inspection certification will need to be issued to comply with the legislation.

This calculation takes the pressure rated in bars and this is multiplied by the capacity of the tank in litres. This is commonly found on a plate on the receiver.

e.g. MWP 11 bar 50 litres capacity

In this example, the MWP (maximum working pressure) is 11 bar multiplied by the 50 litre capacity, which gives a rating of 550 bar litres.

1 bar is equivalent to approximately 15 psi. As a general rule, air receivers with a diameter in excess of 12 inches operating at 150 psi will need to comply with all of the legislation.

The other components of the air compressor set (i.e. compressor and motor) do not need a statutory inspection. If an air compressor has no receiver it does not need an inspection. Hydrovane manufacture compressors have no receivers and are consequently exempt from written schemes and inspection by a competent person.

Q. What is the difference between an air receiver and an air compressor? Do they both need an inspection?

An air compressor has three component parts:

- Driving motor
- Compressor - which compresses the air
- Air receiver - a pressure vessel, which stores the compressed air.

The air receiver is the only part of the air compressor unit that needs a 'statutory' examination. The air compressor and driving motor do not need an inspection - but should be regularly serviced and maintained by the user.

Some air compressors only have two components - a driving motor and an air compressor. The delivery of compressed air is immediate and the need to store air in a pressure vessel is not required. Because these compressors do not have an air receiver they do not need examination.

The term 'compressor' is also used for refrigeration compressors on fridges, cold stores, freezers and air conditioning systems. Refrigeration compressors only require examination under regulations where the driving motor exceeds 25kW. The majority of commercial cold stores operate using motors well below this limit.

Q. How often do air receivers need to be examined?

An examination usually takes place once every 24 months. However the type and frequency of examination are defined by the written scheme.

With the agreement of the customer, and where risks allow it, the written scheme can be written so that both the out of service and external examination are completed at the same time and therefore only one examination takes place - every two years.

Q. The out of service examination highlighted a serious defect which has now been repaired, does the item need to be examined again?

The item should be examined during the repair and a final examination carried out on completion of the repair.

Electrical

Definitions

System means an electrical system in which all the electrical equipment is, or may be, electrically connected to a common source of electrical energy and includes such source and such equipment.

Danger means risk of 'injury' which in turn means death or personal injury from any part of the 'electrical system'.

Relevant Legislation

The Electricity at Work Regulations 1989 contain a comprehensive list of legal requirements designed to prevent the risk of death or personal injury from the use of electricity at all places of work, regardless of size or number of employees.

The regulations require all systems to be maintained so as to prevent danger. Furthermore HSE guidance states that regular inspection and testing is an essential part of any maintenance programme. Regulation 6 of PUWER also requires that work equipment, which may be subject to deterioration liable to result in a dangerous situation, requires inspection at suitable intervals.

The current version of BS7671 'Requirements for Electrical Installations' (the Institute of Engineering Technology (IET) Wiring Regulations) is the accepted general guidance for the design and maintenance of electrical installations. Various other documentation also exists concerning the use of electricity in mines, quarries, petro-chemical installations and places of entertainment.

Examination Frequency

The examination frequency is dependent upon the type of business and the risks presented but is typically once every three or five years. Some trades may require annual examination for licence purposes (for example, places of entertainment, petrol stations, and nursing homes).

The main purpose of our examination is to identify serious defects likely to create an imminent risk of injury to any person.

Manufacturing (including agriculture)	36 Months
Chemical and Petrochemical works	12 Months
Docks and other plants with the presence of water	12 Months
Schools, Hospitals, Hotels, Shops and Offices	60 Months
Quarries	6 Months
Theatres and Leisure facilities	36 Months



Wiring Circuits

It is hard to imagine any location that does not incorporate an electrical wiring installation of some form. Even a storage warehouse will have some basic electrical power requirements such as lighting, heating and a security system. Larger locations will have a complex distribution network required to deliver the demands of electrically driven plant and equipment.

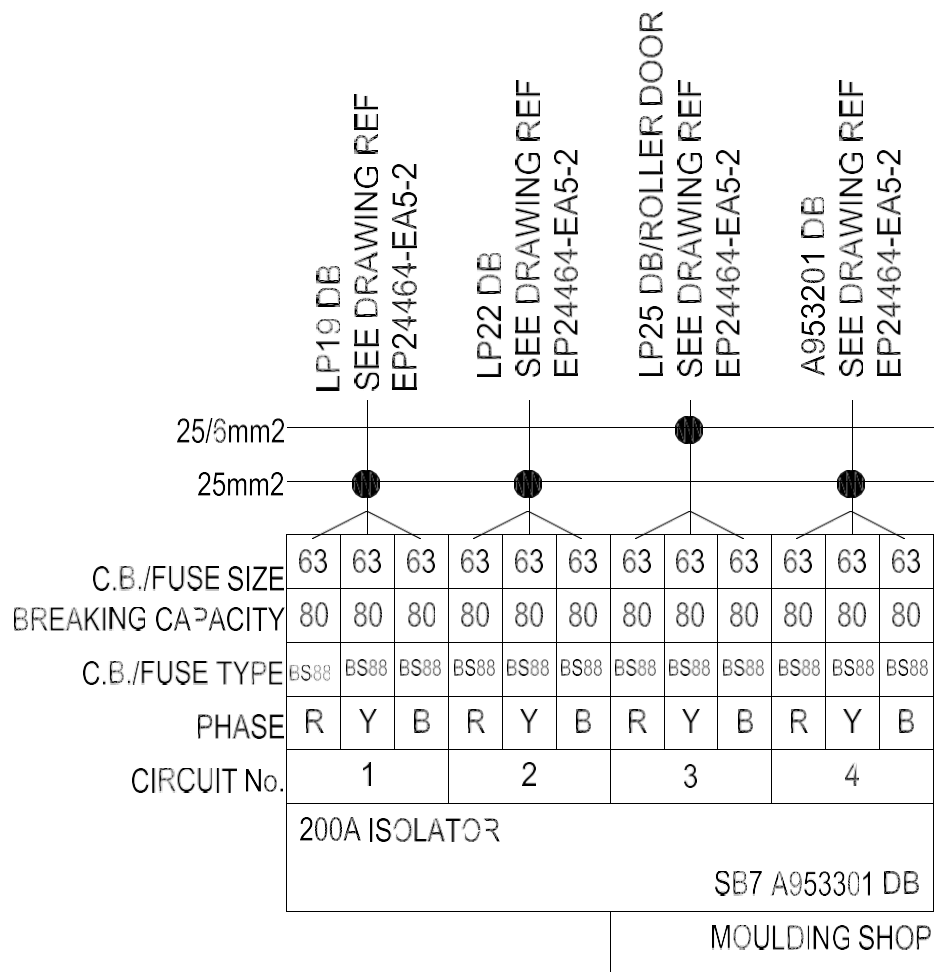

Motors

Motors can be found in most commercial and industrial locations and have a massive scope of physical size and power.

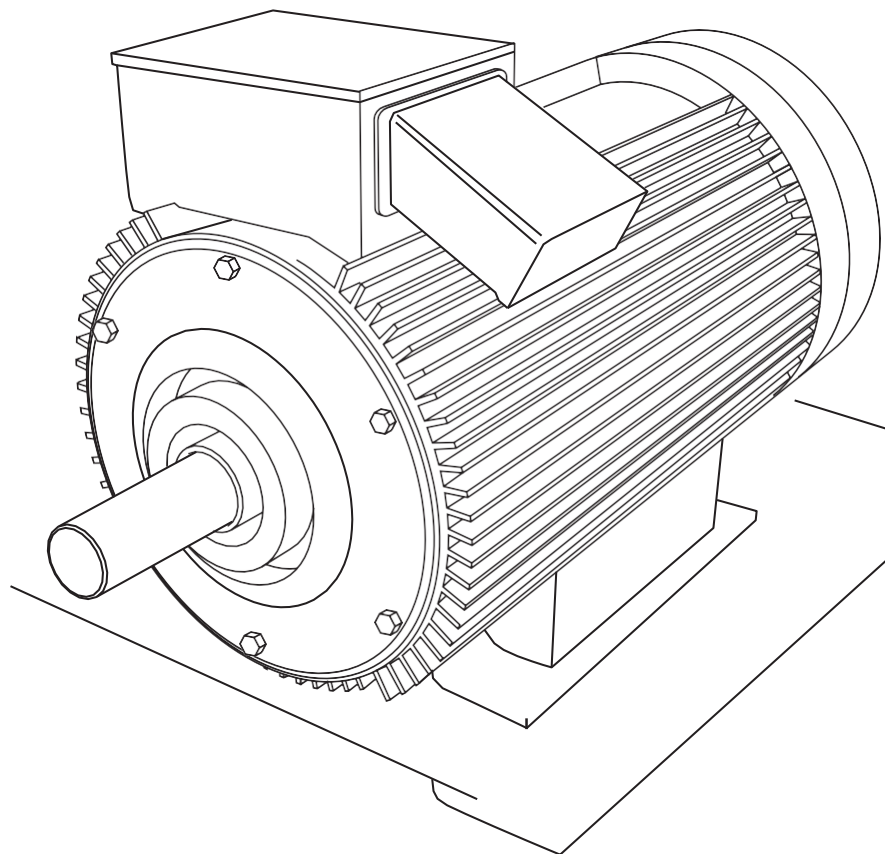

Air Handling Plant

Air handling plant is used extensively in commercial and industrial installations to control the flow of temperature-controlled air throughout a location. Sizes can range from small units, hidden within an office's false ceiling, to very large units in plant rooms or rooftops.

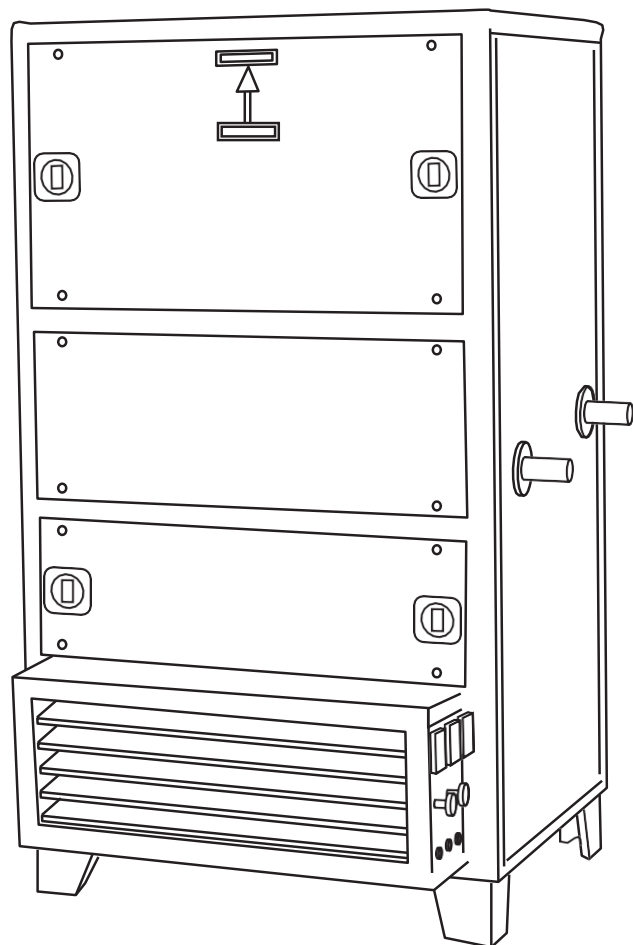

Transformers

Transformers are found in most industrial locations and can be 'step down' or 'step up' depending on voltage requirements. Electricity is carried across distances at high voltage and 'stepped down' using a transformer where it is distributed at low voltage to various sources of application.

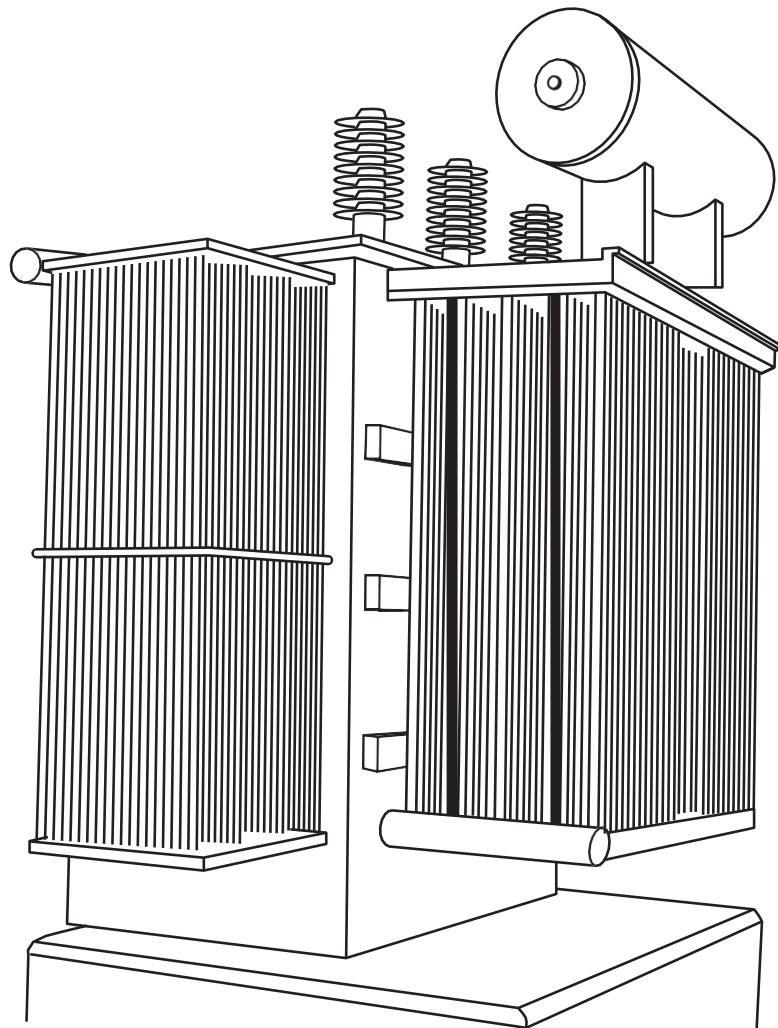

Switchboard

The switchboard is commonly the main control station for the distribution of electrical supply to a location. Switchgear is a heavy-duty switch designed to make and break the main electrical supply to a location or large item of machinery.

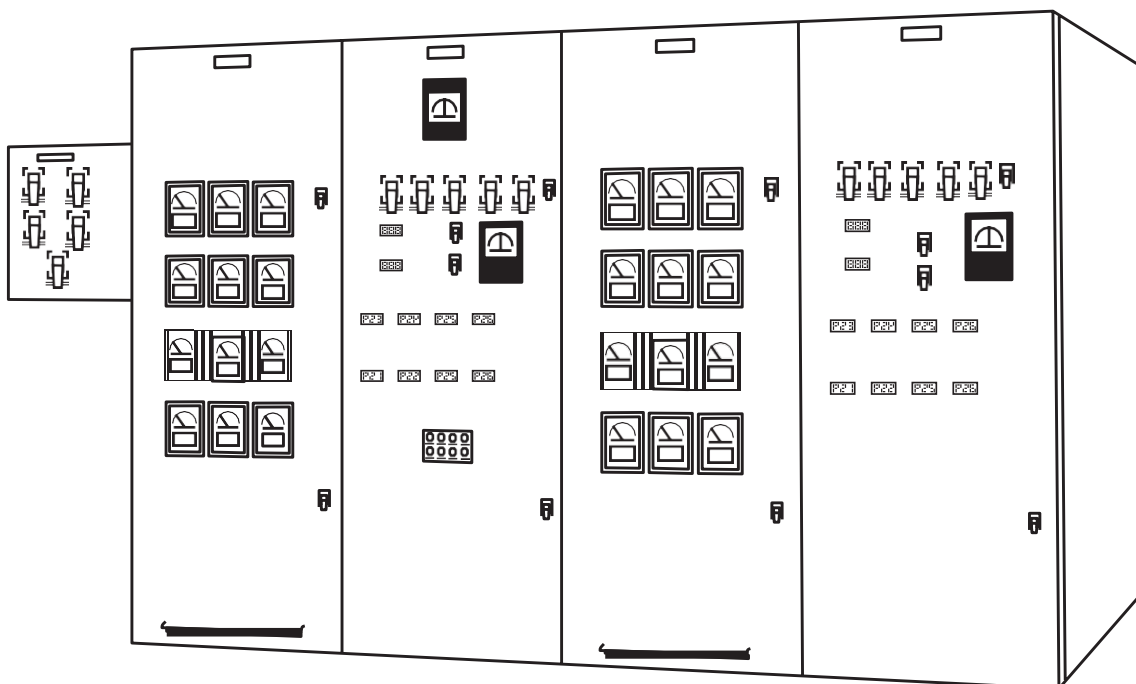

Frequently Asked Questions

Q. What responsibilities do businesses have for electrical systems?

The Electricity at Work Regulations 1989, contain a comprehensive list of legal requirements designed to prevent the risk of death or personal injury from the use of electricity in all places of work, regardless of size or number of employees.

The regulations require 'all systems to be maintained so as to prevent danger'. Furthermore, HSE Guidance states 'regular inspection and testing is an essential part of any maintenance programme.'

The main purpose of the examination service offered by MAT Engineering Services Limited is to identify serious defects likely to create an imminent risk of injury to any person.

The extent of our examination covers the accessible parts of the low voltage distribution system including power and mains lighting installations.

Our service does not normally include the fixed electrical plant or portable appliances, but we can quote for these separately.

The examination frequency is dependent on the type of business and the risks presented, but is typically once every three or five years. Some trades may require annual examination, for example, places of entertainment, petrol stations and nursing homes.

Local Exhaust Ventilation

Definitions

Local Exhaust Ventilation (LEV) is equipment that controls, captures or contains airborne releases at 'or close to' the point of emission by means of ventilation and conveys the pollutant to a point where it can be safely collected or released.

Relevant Legislation

The Control of Substances Hazardous to Health Regulations 2002 (COSHH) apply to all work activities where substances hazardous to health are produced. The regulations state that, 'every employer shall ensure that the exposure of his employees to substances hazardous to health shall be prevented, or where it is not reasonably practicable, adequately controlled.' Where a control needs to be applied, local exhaust ventilation is employed.

The following regulations also impose duties to provide and maintain LEV equipment to control airborne contaminants:

- The Control of Asbestos at Work Regulations 2012
- The Control of Lead at Work Regulations 2002.

Examination Frequency

The COSHH regulations require that LEV plant is examined by a competent person and this examination should be completed at intervals dependent on the trade/business and the application of the equipment.

For example:

- Metal /shot blasting of raw castings require an examination every month
- Non-ferrous metalworking requires an examination every six months
- All other applications require an examination every 14 months.

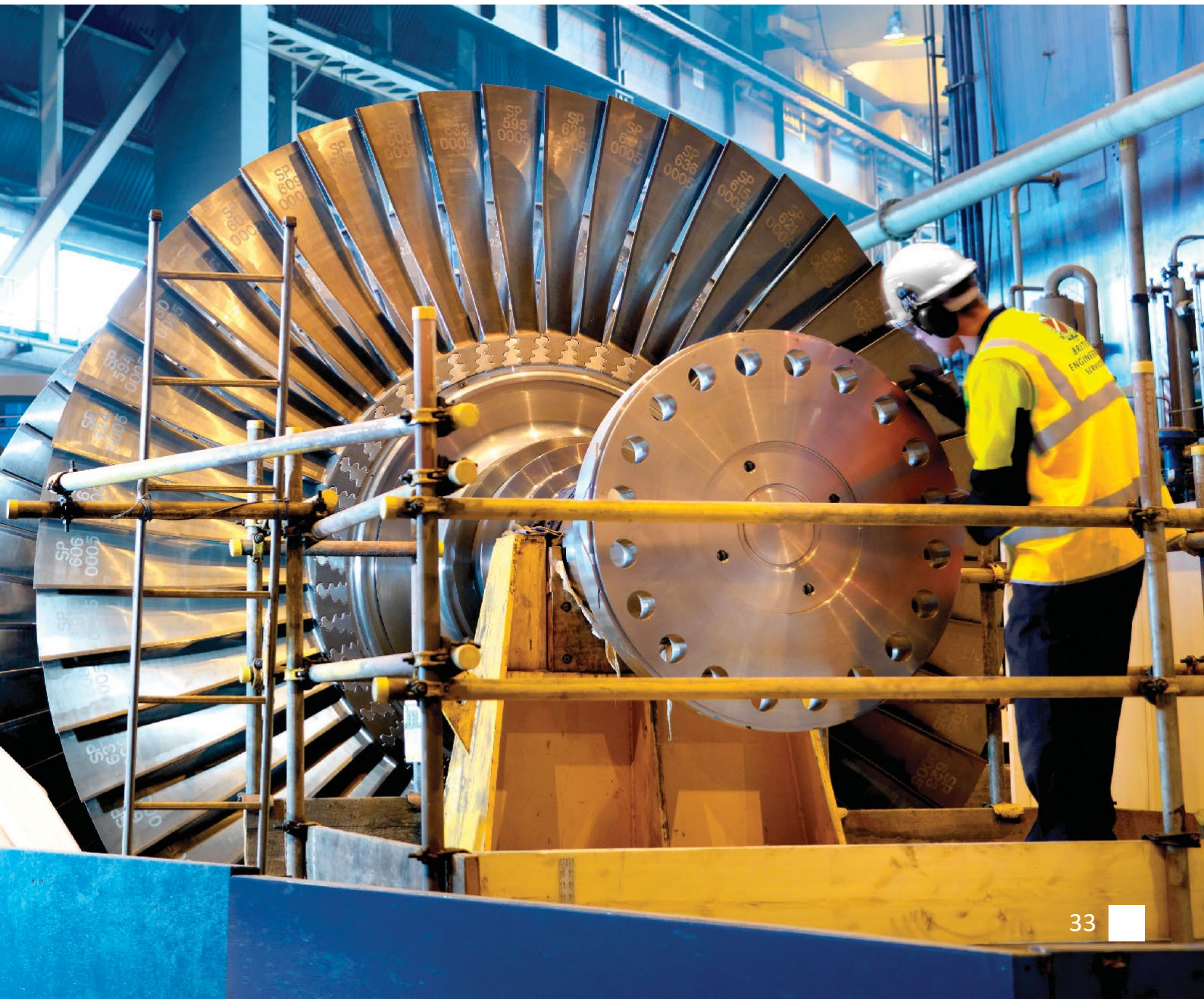

LEV Systems

LEV systems use extract ventilation to prevent or reduce the level of airborne hazardous substances from being breathed in by people in the workplace. They draw pollutants away from a process or operation that is likely to release a hazardous substance into the workplace and consists of an inlet such as a hood, slot, booth or cabinet placed around or close to the point of release of the substance.

The inlet is connected to a fan or air mover and the extracted air is usually discharged into the atmosphere or returned to the workplace after having being cleaned to make it safe for release.

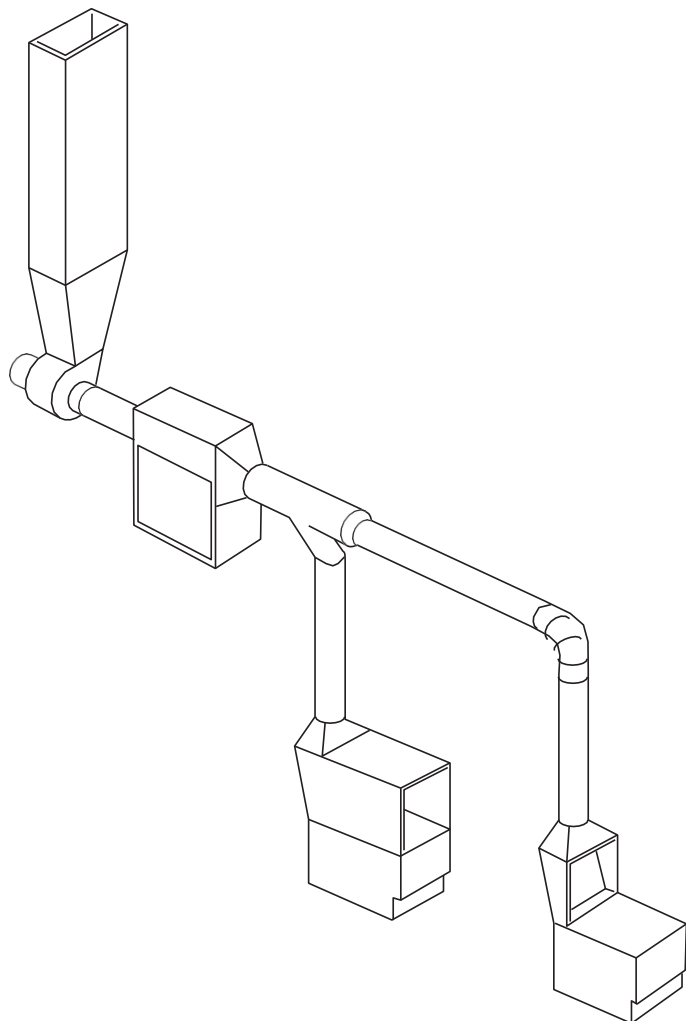

Fume Cupboards

Fume cupboards are partially enclosed workspaces that limit the spread of fumes to operators and other persons in close proximity. Fume cupboards are fitted with a vertically sliding sash, which can be adjusted to vary the degree of the enclosure. Aerodynamic design is as important as the face velocity in ensuring that the contaminant is effectively controlled and released safely.

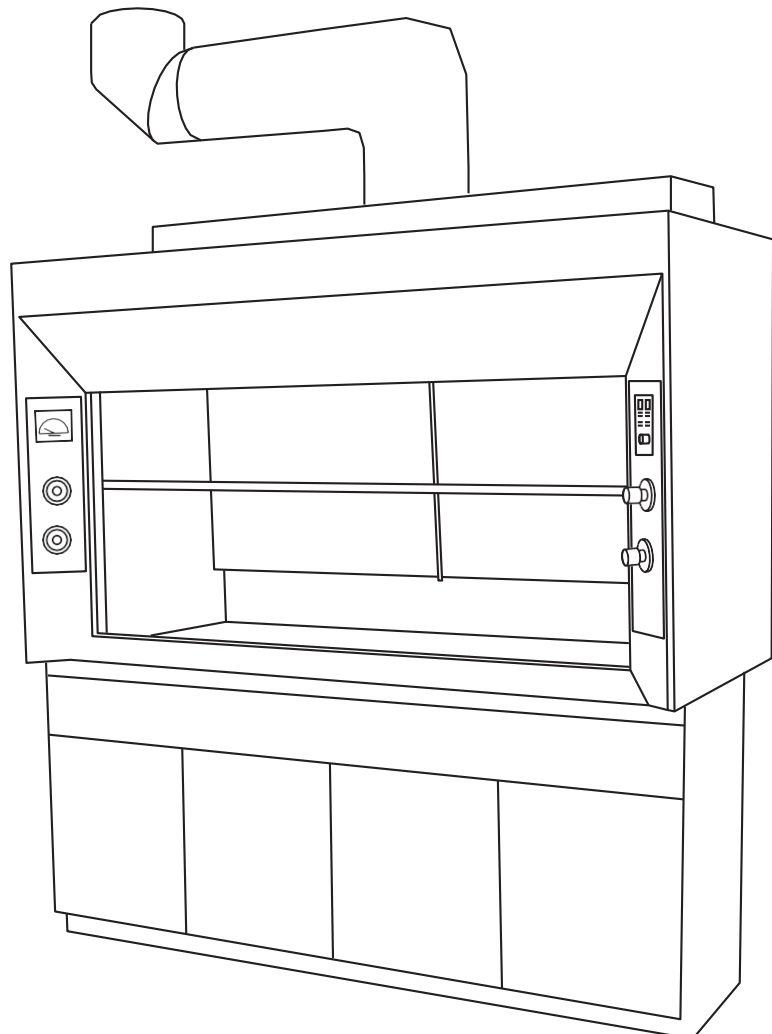

Spray Booths

Spray booths and enclosures are widely available. There are many different designs depending on the type and size of the article being sprayed. Spray booths can be broadly classified by the method of ventilation (side or down-draught air flow) or the method of removing particulate from the exhaust air (water wash, baffles or dry filters).

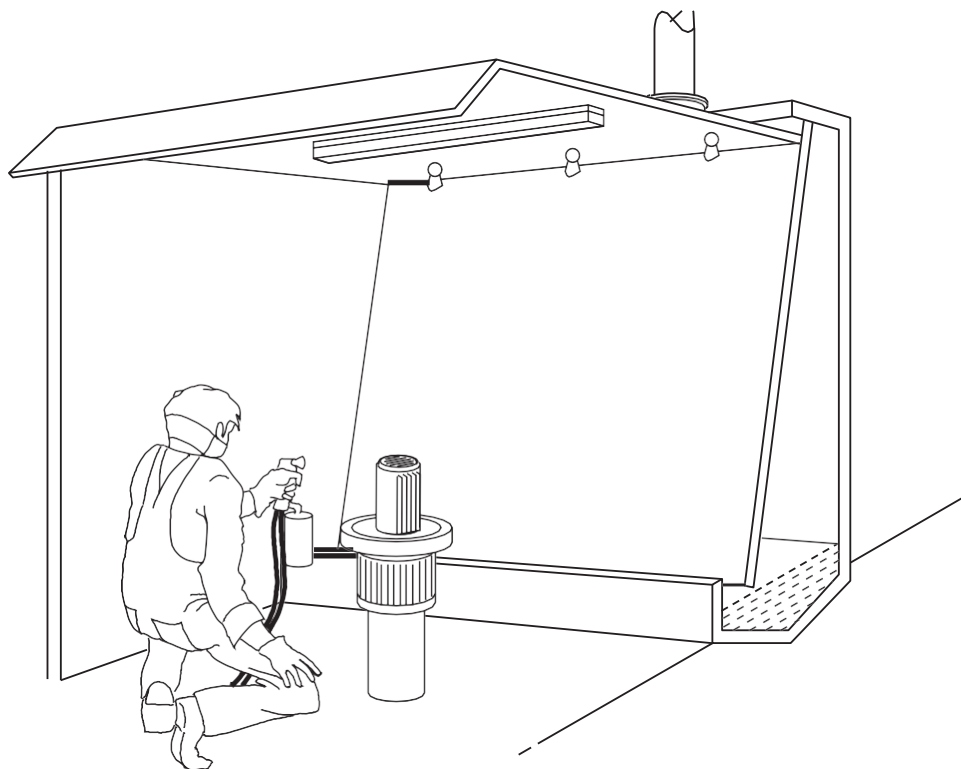

Frequently Asked Questions

Q. Does LEV equipment need an examination?

LEV plant is found in a range of trades from small garages and paint shops to major woodworking and metalworking industries. The equipment is designed to remove the harmful vapour, dust or fumes from the work area identified after a COSHH assessment.

The COSHH regulations require that LEV plant is examined by a competent person, this examination should be completed at intervals dependant on the trade/business and the application of the equipment. For example, metal/shot blasting requires an examination every month but non-ferrous metal working equipment requires an examination every six months.

Q. What is the 'Intended Operating Performance?'

The intended operating performance is usually set at the time of the initial appraisal.

The initial appraisal serves two major functions. Firstly, to show that the plant works and meets its specified performance to control exposure. Secondly, to determine the operating parameters or 'intended operating performance' that will provide satisfactory levels of control. The initial appraisal will form part of the assessment of health risks to comply with Regulation 6 of COSHH.

Power Presses

Definitions

Power Presses are power driven mechanical presses which have a flywheel and clutch and are used wholly or partly to work cold metal.

Interlocking Guard Systems prevent actuation of the press until the guard screen is fully closed or, in the case of a photo-electric guard, the screen has been cleared of any obstruction.

Relevant Legislation

Examination requirements for power presses are within the Provision and Use of Work Equipment Regulations 1998 (PUWER). Part IV of PUWER deals specifically with these requirements and is supported by an Approved Code of Practice.

The regulations require users of power presses to appoint a person to set tools and carry out a simple inspection of the press during every working shift. There is little difference between PUWER part IV and the Power Presses Regulations 1965 & 1972, which PUWER 1998 Part IV revoked.

Examination Frequency

The inspection frequencies for power presses and press brakes with interlocking, automatic or photo-electric guards. These must be subject to a thorough examination every six months. Items with fixed fences must be examined at 12 monthly intervals. There is no flexibility in the regulations to apply a risk based approach to power press examinations. Hydraulic presses do not fall into the scope of PUWER part IV but are treated as such for best practice.

Power Presses

Power presses are power driven mechanical presses or press brakes, which have a flywheel and clutch and are wholly or partly used to work metal. Power presses are among the most dangerous machines used in industry. Amputation or serious injury usually results from accidents caused by trapping between the tools of a power press. The varied work demands on power presses and the wear to which the guarding mechanisms are subject means that the integrity of the guarding is constantly under threat.

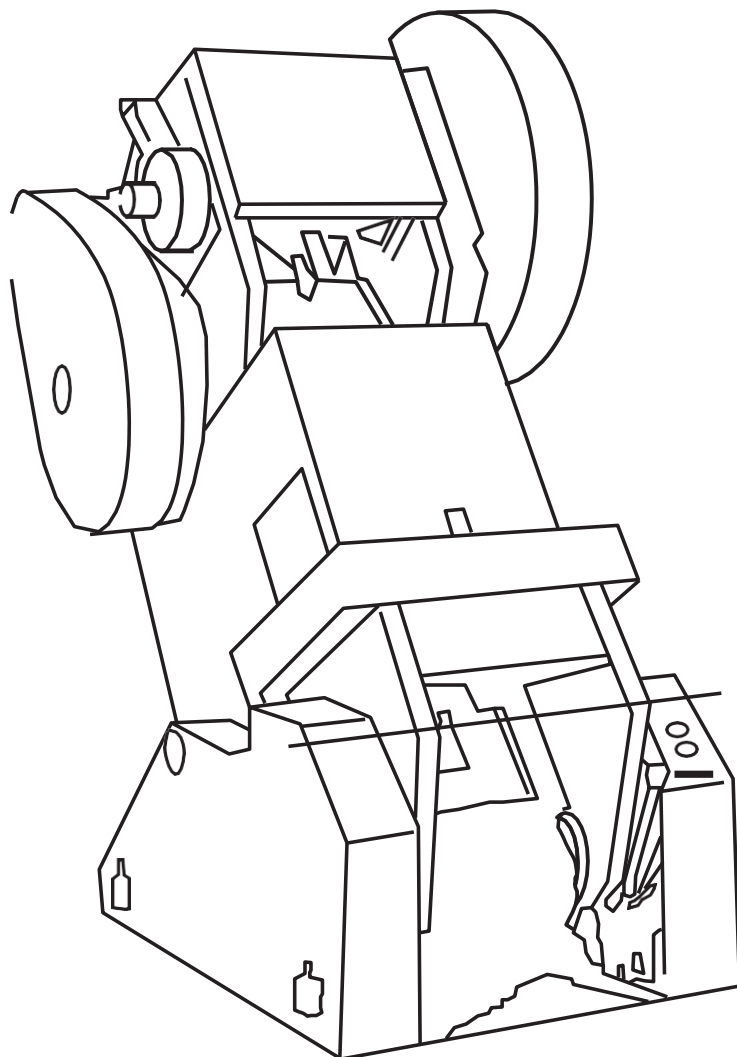

Press Brakes

Press brakes are a subset of power presses with the same examination, inspection and maintenance requirements.

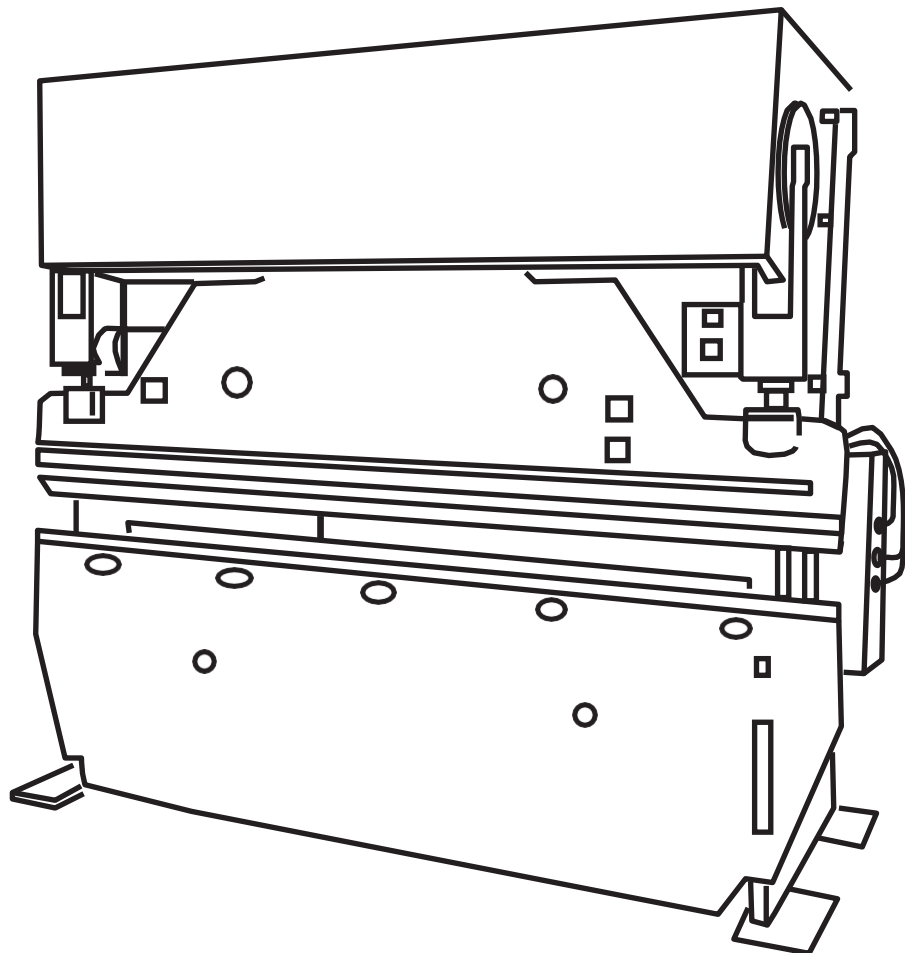

Guillotines

Whilst guillotines and hydraulic presses with interlocking guards do not come under the regulations that cover power presses, they are considered to be dangerous machines and guidance dictates that they should be examined at least once every six months when fitted with interlocking or photo-electric guards.

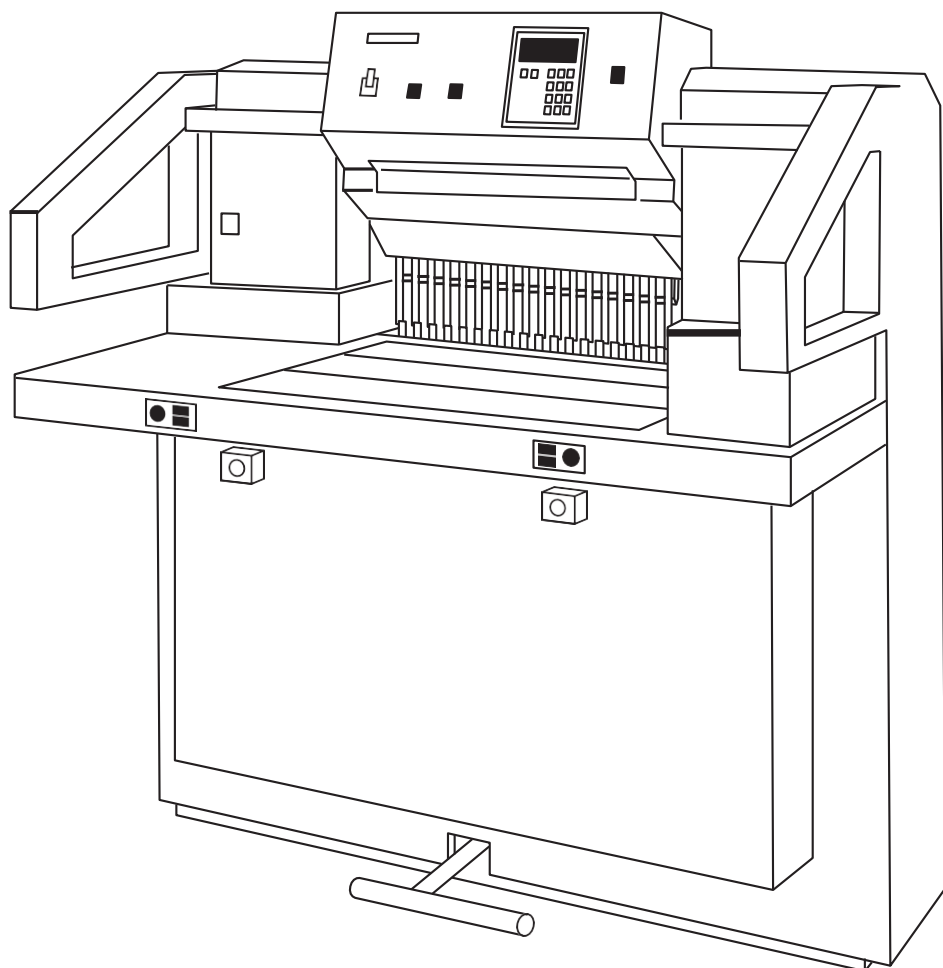

Frequently Asked Questions

Q. Do power presses and press brakes need an examination?

What are my responsibilities as a user?

These machines are used to work metal in a variety of industries from small metal fabrication companies to major car and engine manufacturers. Their capacity can range from small 'bench' type presses at half a ton to presses which impart 12,000 tons of pressure.

They are mechanically driven and in the case of a power press, operate using a clutch and flywheel. A power press clutch is a device designed to impart the movement of the flywheel to any tool when required.

An important aspect of power presses and press brakes is the guarding employed to protect the user. The type of guards can vary from fixed, to movable, to electronic or photo-electric devices and the type of guard determines how often presses are examined.

Regulation 32 of PUWER requires power presses and press brakes to be examined by a competent person and this examination should be completed at intervals dependent on the type of guards fitted to the press. As a general rule the frequency is every 12 months for presses with fixed guards, and at six monthly intervals for all others.

Q. Do I have to dismantle the clutch on my power press for every examination?

No. The competent person will require you to dismantle parts of the press but the frequency for this work is dependent upon many factors including the press duty, the operating environment and the general condition of the press. The engineer will not be able to complete the thorough examination until the work has been done.

Q. Do I have to inspect the press myself?

Yes. You must designate an 'appointed person' to inspect and test the guards and safety devices on each press every day that they are in use (within the first four hours of each working period) and after setting, resetting or adjustment of the tools. The appointed person must be adequately trained and competent to do the work on each type of press.

Other Work Equipment

Definitions

Work equipment means any machine, appliance, apparatus, tool or installation for use at work.

Inspection is that task which determines if the work equipment can be operated, adjusted and maintained safely and that any deterioration can be detected.

Relevant Legislation

The Provision and Use of Work Equipment Regulations 1998 (PUWER) covers the use, maintenance and inspection of all work equipment. PUWER Regulation 6 requires that where the work equipment can deteriorate to a dangerous level it must be inspected at suitable intervals. The intervals will depend upon the risk and the rate of deterioration. The extent of the inspection will also depend on the potential risks and must be carried out by a person competent for the task.

The definition of work equipment is very wide and covers almost everything used during work activity. The inspection required under PUWER Regulation 6 will also vary considerably from a simple user check, which would verify functionality, to a much more involved inspection by an independent third party such as MAT Engineering Limited.



Examination Frequency

The type and frequency of inspections required is not specified within the regulation but will depend on installation and how quickly machinery or safety devices are likely to deteriorate and give rise to a significant risk to the operator or other workers.

In addition, appropriate Standards, or Government and Trade Association Guidance Notes, will contain relevant information, which may be used to determine the required inspection frequency for a wide variety of process machinery.

With the exception of escalators (6 months) general work equipment is subject to 12 monthly inspections unless a risk assessment dictates otherwise.



Dock Levellers

Dock levellers are designed to accommodate a wide variety of lorry tailboard heights and as such are, in effect, adjustable loading ramps. Hinged to and forming an integral part of the loading bay floor, the free end of the dock leveller/ramp is adjusted to suit the height of the incoming lorry tailboard. This allows goods to be loaded/unloaded with the use of fork lift trucks or pallet trucks.

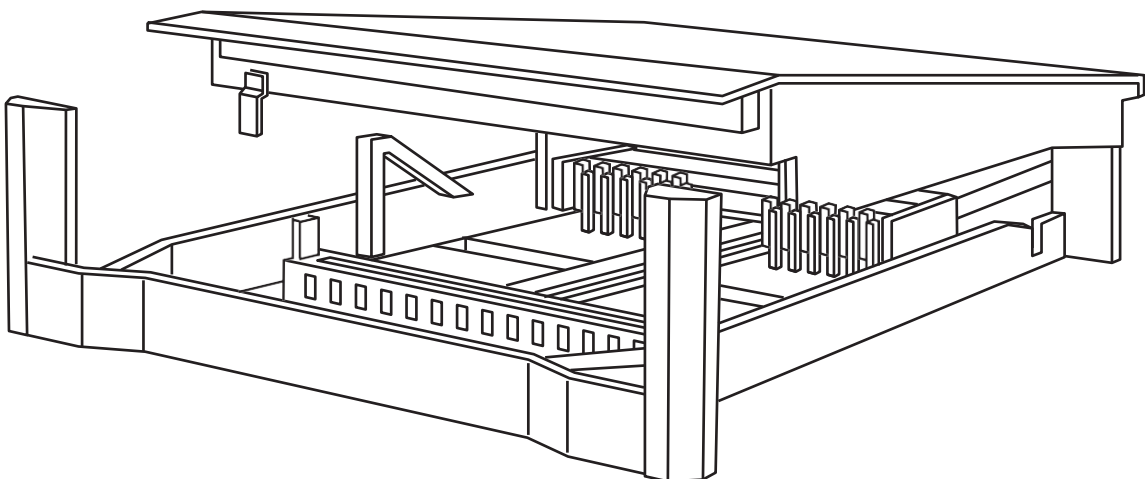

Conveyor Systems

Conveyor systems are mostly powered by diesel engine or an electricity supply. They are used in many industry sectors and utilise a continuous belt or roller arrangement as a means to transfer goods from one level to another. They can be either inclined or horizontal. LOLER would not generally apply except as 'best practice'.

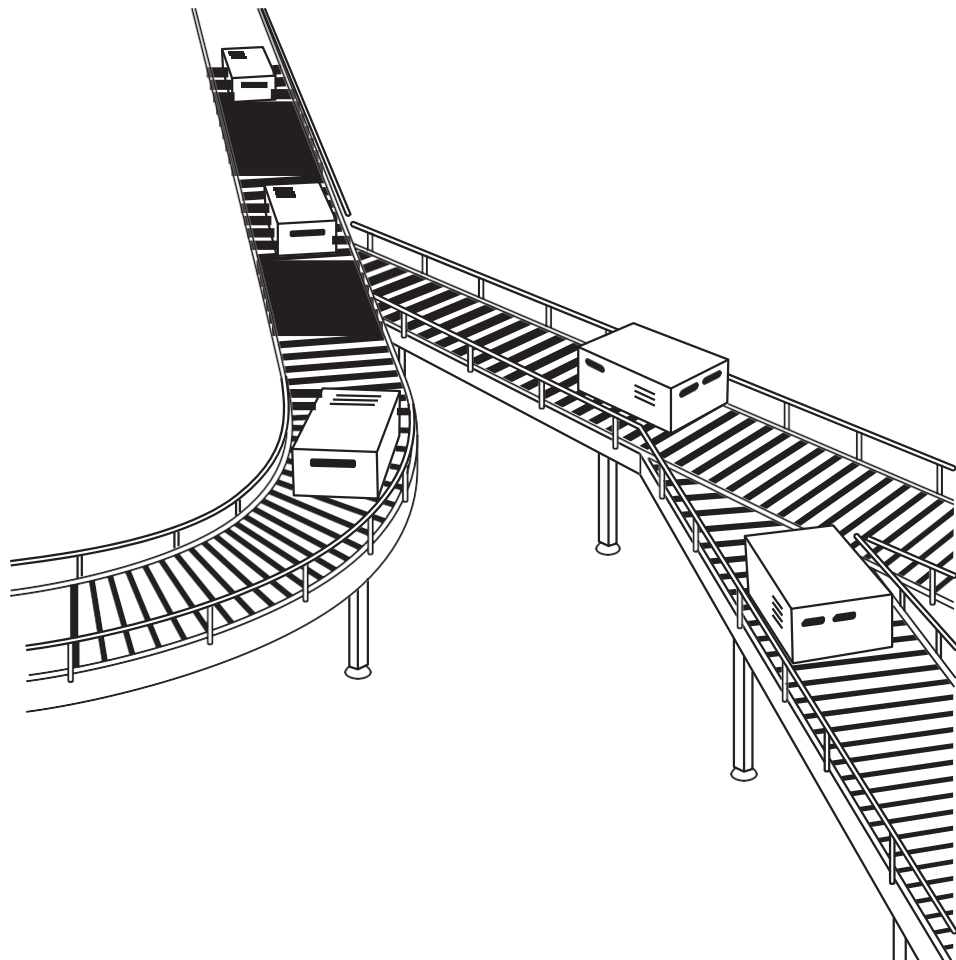

Tractors

Tractors are found in a variety of industrial applications, and can be fitted with many different attachments, which may cause them to require consideration as lifting equipment. With non-lifting attachments they would require inspection as work equipment.

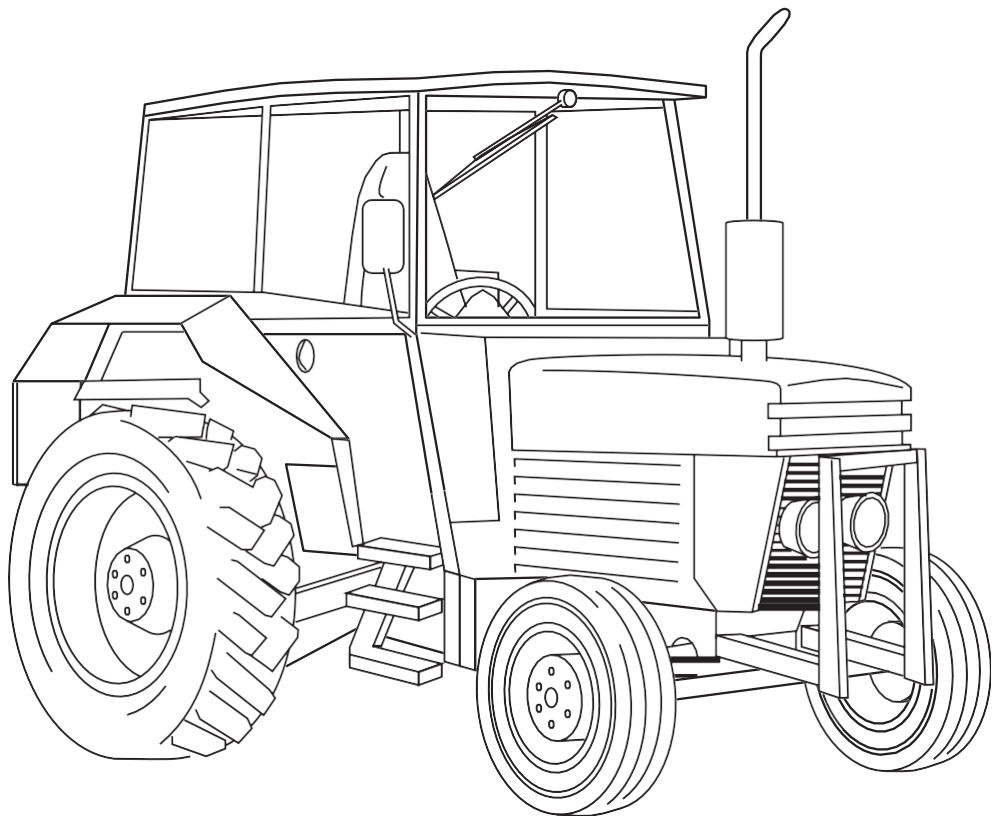

Bulldozers/Loading Shovels

Bulldozers, tractors, graders and scrapers are purpose-built machines used primarily, but not exclusively, in the construction industry. In the most part, this generic group consists of diesel engine tractor units mounted on wheels or tracks. Each variation normally carries a permanently fixed attachment such as a dozer blade or loading shovel etc.

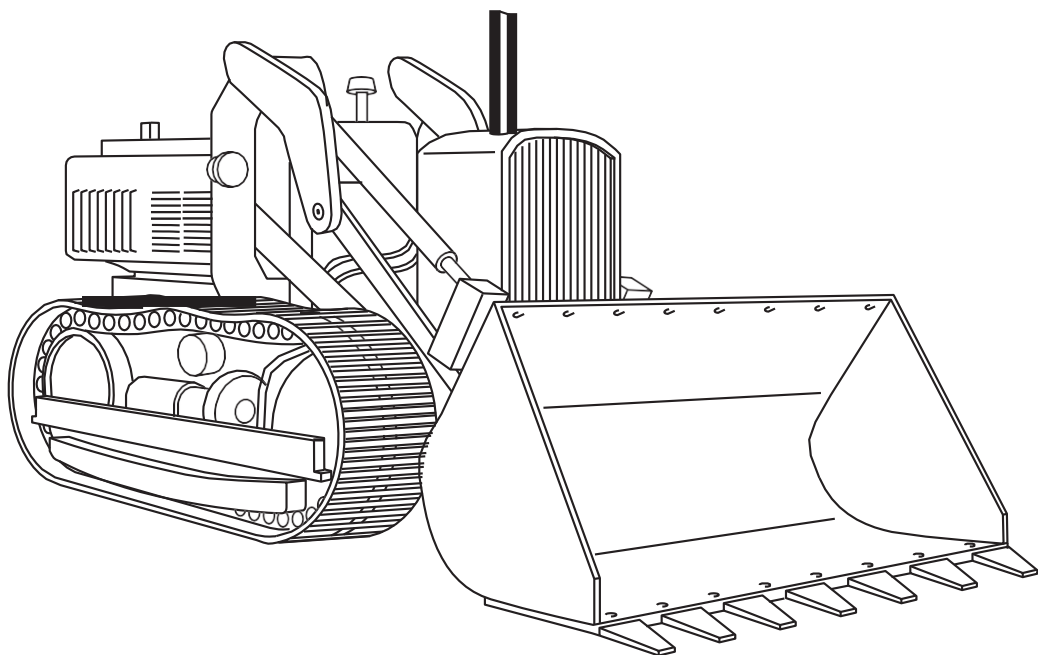

Escalators

Escalators are not deemed to be lifting equipment within the law but are referred to in the Workplace, Health, Safety & Welfare Regulations. Health & Safety Executive guidance recommends thorough examination at intervals not exceeding six months. Escalators are potentially very dangerous machines with many trapping and tripping hazards.

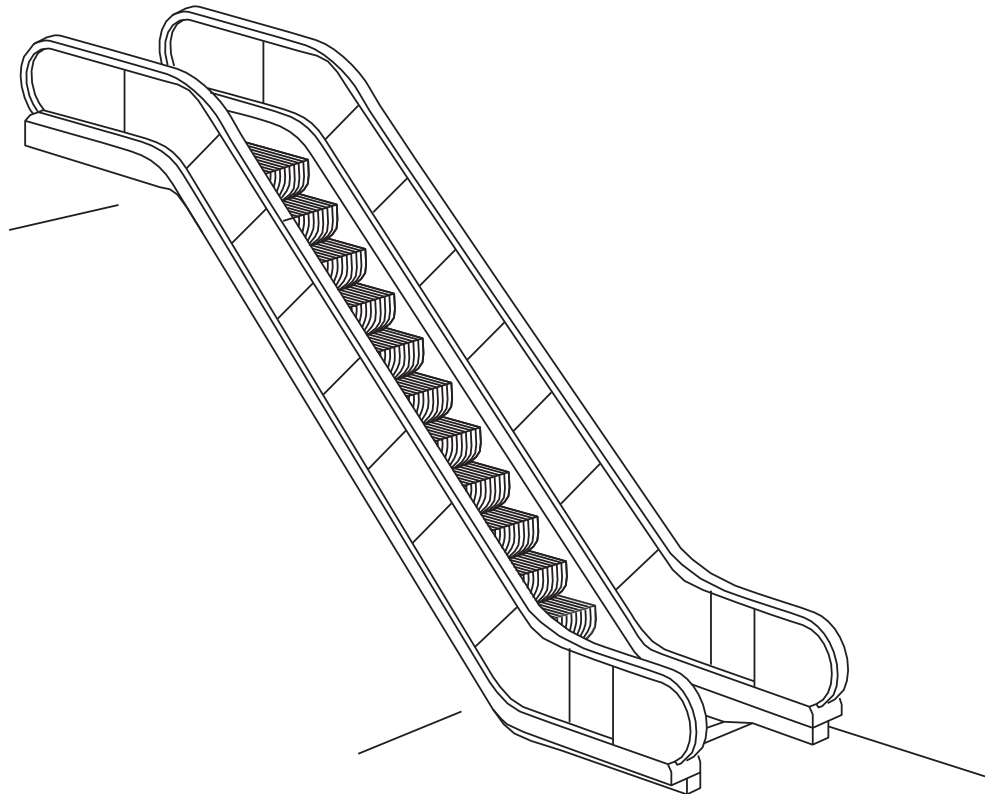

Frequently Asked Questions

Q. How does PUWER 98 affect my business?

The Use of Work Equipment Directive (UWED) was implemented in the UK in 1992 by the introduction of the Provision and Use of Work Equipment Regulations (PUWER).

This directive has been amended and the Amending Use of Work Equipment Directive (AUWED) has been implemented in the UK by two sets of regulations, namely PUWER 98 and LOLER.

PUWER 98 revokes and replaces PUWER and applies to the provision and use of all work equipment including mobile and lifting equipment. PUWER 98 also revokes and replaces legislation relating to Power Presses and Woodworking Equipment. LOLER applies over and above the general requirements of PUWER 98 to those specific activities, which involve lifting equipment and operations.

Approved codes of practice and guidance notes are now available for both regulations. They are both very detailed documents and are available from HMSO Bookshops or from the HSE website.

PUWER 98 applies to employers, the self-employed and people who have control of work equipment. PUWER 98 should be considered alongside other health and safety legislation, in particular the Health and Safety at Work Act 1974 and the general requirements of other regulations to undertake risk assessments and put corrective measures in place.

The term 'inspection' is used within PUWER 98 and should not be confused with the examination undertaken by an independent competent person like a MAT Engineering Limited engineer. 'Inspection' within PUWER 98 for work equipment builds upon the current but often informal practice of regular in-house inspection of work equipment.

'Inspection' does not normally include checks covered by maintenance activity. The purpose of an inspection is to identify whether the equipment can be operated, adjusted and maintained safely and that any deterioration, for example wear and tear, can be detected and remedied before an unacceptable risk occurs.

General Frequently Asked Questions

Q. What is a competent person?

Different levels of competency are defined in HSE regulations. These can cover training, operation of machinery and daily inspection of working parts.

In terms of thorough examinations of machinery and plant to find defects likely to cause damage, the competent person is generally defined as:

A person who has the appropriate practical and theoretical knowledge and actual experience of the plant he is examining to enable him to detect defects or weaknesses and to assess their importance in relation to the safety and continued use of the plant.

In some regulations the academic qualifications of a competent person are clearly defined. In other regulations it is stressed that the competent person must be sufficiently independent and impartial to allow objective decisions to be made.

This definition of competency for plant examinations has been tested following numerous court cases. It is not sufficient that you have used the item of plant for many years, or if you are the person who regularly maintains the machine. You must have the theoretical knowledge, as well and be sufficiently independent, so that no conflict of interest exists.

For example, if you are the person maintaining the machine you may be unlikely to report any serious defect to the HSE.

Q. What constitutes a serious defect?

For pressure equipment, the term 'serious defect' is used to describe a defect found at the time of examination that presents an 'imminent danger' to persons working in the vicinity. For lifting equipment the term 'serious defect' involves 'an existing or imminent risk of serious personal injury' to persons using the machine or working in the close vicinity.

The competent person who undertakes the thorough examination and identifies such defects will report them as requiring attention either immediately, or within a specified time period. When the regulations require it, he will forward a copy of his examination report to the relevant enforcing authority - typically the local Health and Safety Executive.

Examples of serious or safety related defects include:

- Defective safety components such as safety valves or overspeed governors
- Worn or wasted structural components such as forks, chassis or pressure envelopes
- Damaged lifting ropes or chains
- Incorrect or bridged fuses.

Other 'defects' may also be identified during an examination, which are not considered to present any danger to persons. These other defects and observations will normally receive attention at the next routine maintenance of the equipment and because they are not felt to provide an imminent risk of injury they are not reported to local enforcing authorities.

Q. The engineer sent a copy of the serious defect report to HSE.
Does he have to do this?

Yes. As the competent person he is duty bound under the relevant regulation to send a copy report to the enforcing authority within a specified time limit if, in his opinion, the defect is likely to cause imminent danger to the person using the machine or persons working in the vicinity.

However, this should never be a surprise to the customer as the engineer will always explain the defect, its seriousness in relation to the continued use of the plant, and he will leave a hand written note at the time of his visit detailing the problem(s).

When the HSE call on the customer it will reflect badly if they have taken no action to remedy the situation. If they have already repaired or have made arrangements to replace the defective item, this is often sufficient to satisfy the HSE inspector and no further action is normally taken.

Q. What is an EC Declaration of Conformity?

An EC Declaration of Conformity is issued with new products which legally need to comply with any relevant EC Product Directive before the product can be supplied in the UK or anywhere else in the European Community.

Fork lift trucks are manufactured in line with the Machinery Directive and air receivers must comply with the Pressure Equipment Directive. The Declaration of Conformity, along with CE marking, is confirmation that the product meets the essential requirements for safety.

The Declaration lasts for the lifespan of the machine unless major alterations are made. It must be passed to any new owner when the item is sold.

For lifting equipment the declaration allows new plant a short period of exemption for thorough examination. This is normally 12 months providing safety does not depend upon installation conditions.

Q. I have a brand new item of plant. Does this require an inspection prior to being put into service?

If it is pressure plant, for example an air receiver or steam boiler, the answer is yes. If it is lifting plant and safety does not depend upon installation conditions - when the declaration of conformity initial period has expired - an inspection is normally required 12 months after being purchased.



Q. Can thorough examinations be carried out by the maintenance company?

Yes. However, plant owners must ensure that the competent person who undertakes a thorough examination has appropriate practical and theoretical knowledge.

He must also have experience of the equipment to be thoroughly examined in order to detect defects and weaknesses and to assess their importance in relation to the safety and continued use of the equipment.

It is essential that the competent person is sufficiently independent and impartial to allow objective decisions to be made. This does not mean that competent persons must be necessarily employed from an external company. If employers and others within their own organisations have the necessary competence they can use it.

However, they must ensure that their examiners have genuine authority and independence to ensure that examinations are properly carried out and that the necessary recommendations arising from them are made without fear or favour.

It is generally accepted that enforcing authorities and inspection bodies accredited to 17020, are independent and impartial.

Our Business is Protecting People

We take risk seriously, very seriously. The problem with risk is, it's risky. We don't get to choose the outcome when something goes wrong and we all know it can't be left to chance. We work tirelessly to ensure that choosing to step up to the mark is something we inspire our customers, and the UK industry as a whole to want to do.

The whole reason we exist is to keep people from harm's way and that will never change. Whether it's our customers or our people, they come before everything else. We make sure everyone gets home safe.

MAT Engineering Services are proud to be accredited. Infact, we hope you wouldn't settle for anything less. For you it means complete peace of mind that you've chosen the most robust assurance of best practice. And what's more, we're a founder member of SAFed.

Of course, not all our customers are the same, so we believe in being flexible. Whether the requirement is for single or multiple inspections, or the provision of detailed technical advice at short notice, we work in partnership with our customers to provide a solution that is tailored to suit your business needs.

If you need to see more of us, that's fine, we can arrange for an engineer to spend time on site to help with issues that may change on a day-to-day basis. In addition, our team of Engineer Surveyors can reach sites across the UK at short notice.

We're proud to be MAT Engineering LTD and to us that stands for the highest quality assessments, rigorous inspection and detailed reporting, with no compromise, ever.

We're all about enhanced surveying combined with excellent service and logistics.

We've make Britain a safer place.





Leave nothing to chance.

MAT Engineering LTD, 43 Sutton Road, Watford, WD17 2QE
T 0192 335 0764 E info@matengineering.co.uk W matengineering.co.uk